



Centrifugal Water Chillers

**Model CVGF (For International
Distribution Only)
Water-Cooled Hermetic Centrifugal**

**Refrigeration Capacities From
400 to 1000 Tons (1400 kW-3510 kW)**

50 and 60 Hz

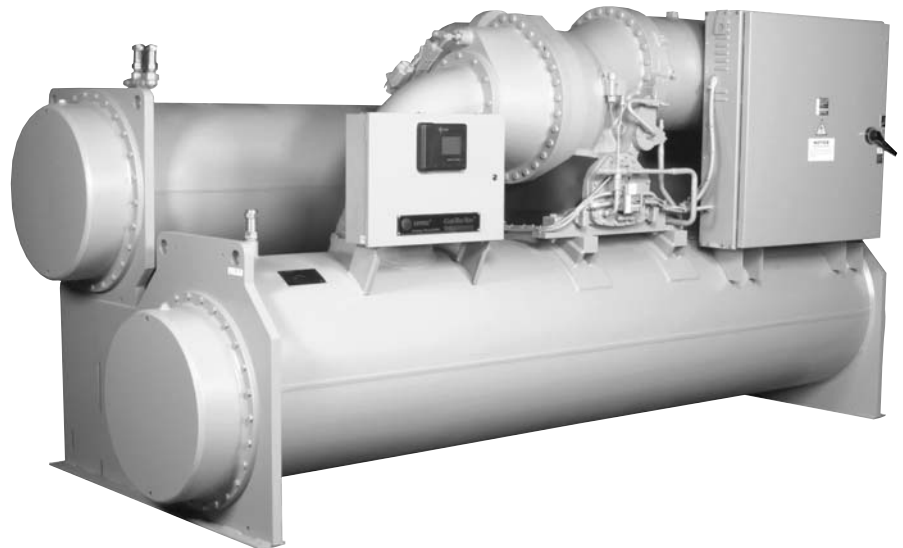



Introduction

Introducing Trane's Model CVGF Centrifugal Water Chiller

Introduction

The basic gear driven centrifugal water chiller design was introduced in 1976 and has been proven in thousands of installations. The Trane Company continues to deliver its reliability and energy fitness commitment on its newest line of gear drive centrifugal water chillers, the Model CVGF. The major advantages of the Model CVGF are:

- High reliability
- Low sound levels
- Compact size
- High efficiency at a competitive market price
- Designed to use environmentally responsible HFC-134a refrigerant.

The Model CVGF chiller is ideal for office, hospital, school, hotel, retail store and industrial buildings. The Trane centrifugal chiller line offers hundreds of individual evaporator-condenser-compressor combination selections, permitting precise tailoring of the machine capacity to system requirements. Machine selections can be computer optimized to provide low first cost, low operating cost or other criteria important for a particular selection. Centrifugal Water Chiller computer selection program is certified in accordance with ARI standard 550/590. Trane Sales Engineers are available to assist in selecting the optimum machine to satisfy the particular project requirements.

Turn to the Model CVGF for energy efficiency provided by the two stage gear drive centrifugal water chillers with economizers. The Trane Model CVGF is your choice for energy fit operation year after year.

Contents

Introduction	2
Features and Benefits	4
Application Considerations	10
General Data	11
Jobsite Connections	13
Controls	14
Physical Dimensions	18
Mechanical Specifications	20
Conversion Table	23

Features and Benefits

Standard CVGF Features

The following features are provided as standard with all Trane Model CVGF chillers:

- Hermetic two-stage centrifugal compressor-motor assembly with integral lubrication system and economizer cycle
- Evaporator and condenser assembly
- Prewired instrument and control panel
- Oil charge
- Integral oil heaters
- Isolation pads
- Wiring and oil system interconnection to main control panel
- Advance motor protection
- Two-stage gear drive with economized cycle for high efficiency and high reliability
- Liquid cooled hermetic induction motor; the motor operates at lower temperatures for longer motor life

Optional Features

- Unit and remote wye-delta mounted starters
- Unit mounted, floor mounted, and wall mounted solid state starters.
- Across-the-line, Primary Reactor, and Auto Transformer Remote mounted starter for medium/high voltage
- Marine waterboxes for evaporator and condenser
- Factory-applied thermal insulation
- One-inch deflection spring isolators for vibration-sensitive installations
- Refrigerant available from a local distributor
- Building automation systems (BAS) Interface
- Factory testing

Applications

- Comfort cooling
- Industrial process cooling

Patents

- Polygon drive for refrigeration compressor impellers
- Centrifugal compressor sump demister
- Internal oil filter
- Thermosiphonic oil cooler
- Compressor height and alignment adjustment
- Oil return using hot gas for motive force
- Centrifugal impeller assembly
- Internal oil filter

Orifice System

- Simplified orifice system with improved part load performance down to 20 percent part load

Advanced Heat Transfer Surfaces

- Evaporator and condenser tubes use the latest heat transfer surfaces
- Less refrigerant needed due to advanced patented evaporator design

Compact Size

- Designed with the retrofit and replacement market in mind
- The 400 to 500 NTON sizes can fit through most double-width doors
- Small footprint of the CVGF chiller saves valuable equipment room space

Simple Installation

- Simplified piping; the only water piping required is for the evaporator and condenser
- Simple power connection
- Unit mounted starter eliminates additional jobsite labor requirements

Environmental Features and Benefits

Improved Efficiency:

- High Efficiency: 0.55 kW/Ton at ARI conditions
- Motor cooling vented to economizer cycle, efficiency advantage
- HFC-134 optimized inlet guide vanes and impellers for improved cycle efficiency using computational fluid dynamics

Reduced Emissions:

- Over 30 percent joint reduction in compressor/motor assembly compared to previous designs
- Patented integral heaters imbedded into the compressor casting, no seals no leaks
- Beaded flat gasket technology instead of O-rings, lower susceptibility to developing leaks
- Minimal NPT pipe threads on chiller system, SAE O-ring boss fitting, lower leak potential
- Oil sump internal to compressor/motor assembly with internal pump/motor; eliminates vent and drain lines, leak prevention
- Patented internal oil filter prevents leaks and contamination from pipes; filter is isolated and easily replaced
- Advanced evaporator design minimizes the refrigerant charge; a reduced charge reduces the exposure to the environment in the event of a catastrophic charge loss

Additional Features and Benefits

- Patented polygon attachment instead of a keyed shaft, self-balancing
- Easy to replace motor terminals
- Motor/stator assembly is easily removed; speed assembly can be removed independent of the high-speed assembly
- Rolling element bearings
- Hydrodynamic bearings
- Advanced evaporator design: no eliminator necessary with an advanced suction baffle design
- All metric fasteners

Features and Benefits

Microprocessor Controls with CH530

DynaView Operator Interface

DynaView™ is the unit-mounted control panel and also serves as the main processor and operator interface. It has a touch-sensitive overlay on a 1/4 VGA display.

DynaView presents information through an intuitive, tabbed- navigation system. Alternate languages can be downloaded to the control panel, which can hold English plus two other languages at one time.

DynaView receives information from and communicates information to the other devices on the chiller's communications link. DynaView performs the Leaving Chilled Water Temperature and Limit Control algorithms, arbitrating capacity against any operating limit against which the chiller may find itself working.

- Auto/Stop commands
- Status (all subsystems)
- Setpoint adjustment (daily user points)
- 10 active diagnostics
- Mode overrides
- ASHRAE chiller log

DynaView can be connected to the service tool using a standard 9-pin male, 9-pin female RS-232 serial cable. The serial connection is located at the bottom of the DynaView panel behind a sliding door.

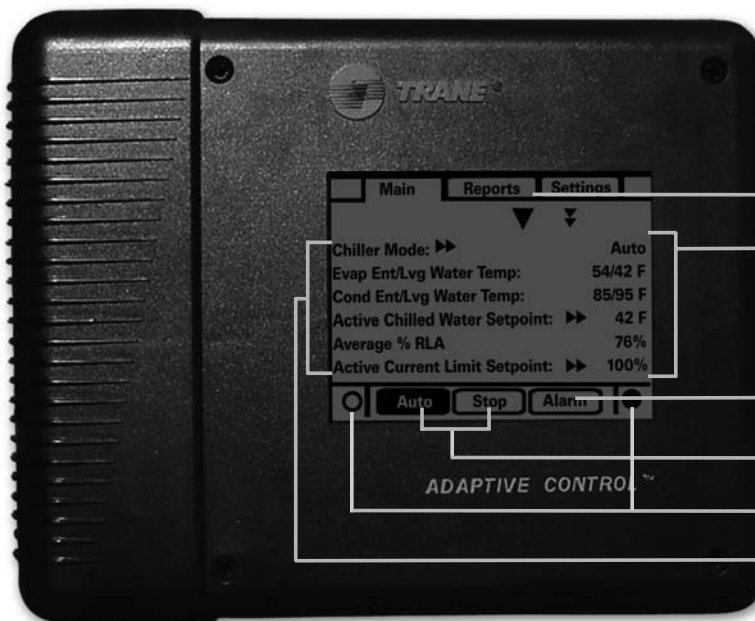

Touch sensitive screen provides information and navigation at the same time

Change setpoints and settings with touch screen commands

Displays chiller status and operating points. Touch for more information

If diagnostic exists, an alarm indicator will appear. Press for detail.

Auto / Stop

Contrast Control

Extensive diagnostics customized to the chiller type installed—centrifugal, helical rotary, or absorption

Features and Benefits

Serviceability

Previous Trane chiller controllers included a user interface that presented all chiller data necessary for both daily tasks and service or maintenance tasks. The amount of information presented on a limited display made a number of tasks difficult. A service technician's ability to assess and resolve chiller problems was hampered by the limited presentation of multiple pieces of chiller information.

The Tracer chiller controller adds a level of sophistication better served by a PC application that improves service technician effectiveness and minimizes chiller downtime. The Tracer chiller controller provides a user interface and main processor, DynaView, that is intended to serve only typical daily tasks. The portable, PC-based service tool software, TechView, supports service and maintenance tasks.

The Tracer chiller controller will be gradually applied to all Trane chillers. TechView will then serve as a common interface to all Trane chillers, and will customize itself based on the properties of the chiller with which it is communicating. Thus, the service technician learns only one service interface.

The panel bus is easy to troubleshoot, using LED verification of sensors. Only the defective device is replaced. Captive screws ensure that the appropriate mounting hardware is available. TechView can communicate with individual devices or groups of devices.

TechView™

All chiller status, machine configuration settings, customizable limits, and up to 60 active or historic diagnostics are displayed through the service-tool software interface. Any PC that meets the system requirements may download the service interface software and DynaView updates from Trane's Web site at www.trane.com.

TechView is designed to run on a customer's laptop, which connects to DynaView with a serial cable. DynaView's serial port is located behind a sliding door on the bottom of the DynaView enclosure. It uses a standard 9-pin male and 9-pin female RS-232 cable.

Hardware requirements for TechView:

- Pentium II, III, or higher processor
- 128 MB RAM
- 1024 x 768 resolution
- CD-ROM
- 56K modem
- 9-pin RS232 serial connection
- Windows® 95, 98, 2000

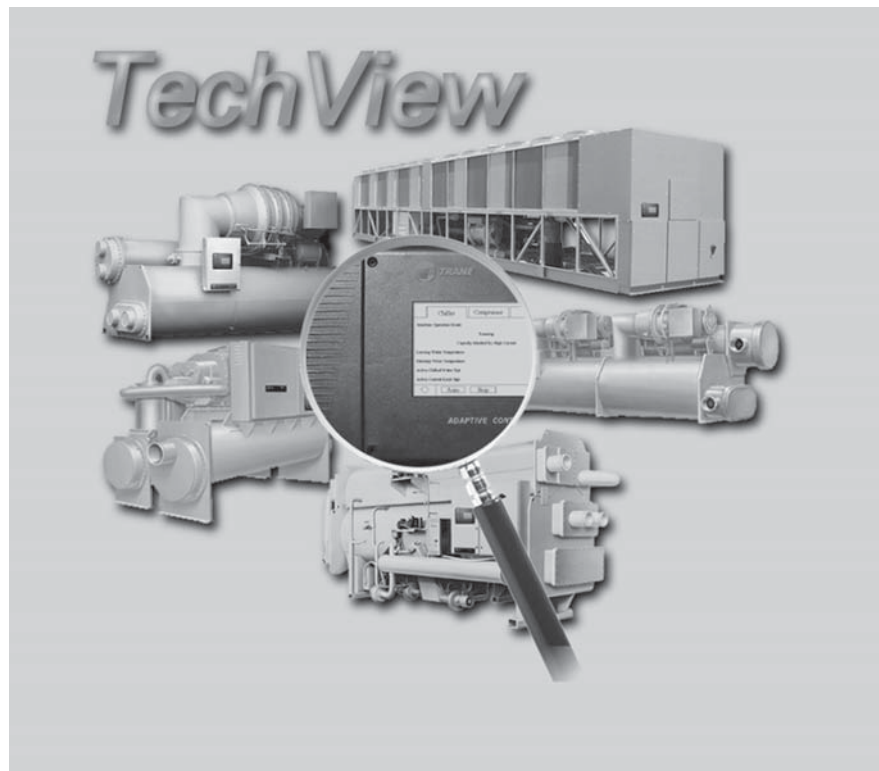

Features and Benefits

Feedforward Adaptive Control

The Tracer chiller controller allows the system designer to explore energy saving strategies and allows the centrifugal chiller to be used in ways that were never thought possible.

Feedforward Adaptive Control

Feedforward is an open-loop, predictive control strategy designed to anticipate and compensate for load changes. It uses evaporator entering-water temperature as an indication of load change. This allows the controller to respond faster and maintain stable leaving-water temperatures.

Soft Loading

The chiller controller uses soft loading except during manual operation. Large adjustments due to load or setpoint changes are made gradually, preventing the compressor from cycling unnecessarily. It does this by internally filtering the setpoints to avoid reaching the differential-to-stop or the current limit. Soft loading applies to the leaving chilled-water temperature and current-limit setpoints.

Multi-Objective Limit Arbitration

There are many objectives that the controller must meet, but it cannot satisfy more than one objective at a time. Typically, the controller's primary objective is to maintain the evaporator leaving-water temperature.

Whenever the controller senses that it can no longer meet its primary objective without triggering a protective shutdown, it focuses on the most critical secondary objective. When the secondary objective is no longer critical, the controller reverts to its primary objective.

Fast Restart

While the inlet guide vanes are closing, the controller will allow the centrifugal chiller to restart and going to a postlube operational mode. If the chiller shuts down on a nonlatching diagnostic, the diagnostic has 30–60 seconds to clear itself and initiate a fast restart. This includes momentary power losses.

Variable Water-Flow Compensation

Water-flow compensation is a new, optional, control feature for centrifugal chiller. It is included with the water flow control option, along with water pressure-sensor transducers.

Building Automation and Chiller Plant Control

For a preprogrammable and flexible building automation and chiller plant control, Trane has developed the Tracer Summit™. It can control the operation of the complete installation: chillers, pumps, cooling towers, isolating valves, air handlers and terminal units. Trane can undertake full responsibility for an optimized automation and energy management for the entire chiller plant.

The main functions are:

- **Chiller sequencing:** equalizes the number of running hours of the chillers. Different control strategies are available depending on the configuration of the installation.
- **Control of the auxiliaries:** includes input/output modules to control the operation of the various auxiliary equipments (water pumps, valves, cooling towers, etc.)

- **Time of day scheduling:** allows the end user to define the occupancy period, i.e. time of the day, holiday periods and exception schedules.
- **Optimization of the start/stop time of the installation:** based on the programmed schedule of occupancy and on the historical record of the behavior of the temperatures, calculates the optimal time of start and stop of the installation to get the best compromise between energy savings and comfort of the occupants.
- **Soft loading:** the soft loading function minimizes the number of chillers that are operated to satisfy the building morning pull down, thus preventing an overshoot of the actual capacity required. Unnecessary starts are avoided and the peak current demand is lowered.



Features and Benefits

- **Communication capabilities:** several communication levels are provided:
 - local, through a PC workstation keyboard. Summit can be programmed to send messages to local or remote workstations and or a pager in the following cases:
 - Analog parameter exceeding a programmed value.
 - Maintenance warning.
 - Component failure alarm.
 - Critical alarm messages. In this latter case, the message is displayed until the operator acknowledges the receipt of the information. From the remote station it is also possible to access and modify the chiller plant's control parameters.
- Remote communication through a modem: As an option, a modem can be connected to communicate the plant operation parameters through voice grade phone lines.

The remote terminal is a PC workstation equipped with a modem and software to display the remote plant parameters.

Chiller-Tower Optimization

Tracer Summit™ chiller-tower optimization extends Adaptive Control™ to the rest of the chiller plant. Chiller-tower optimization is a unique control algorithm for managing the chiller and cooling-tower subsystem. It considers the chiller load and real-time ambient conditions, then optimizes the tower setpoint temperature to maximize the efficiency of the subsystem.

Integrated Comfort™ System (ICS)

The onboard Tracer chiller controller is designed to be able to communicate with a wide range of building automation systems. To take full advantage of the capabilities of the chiller, incorporate your chiller into a Tracer Summit building automation system.

But the benefits do not stop at the chiller plant. At Trane, we realize that all energy used in your cooling system is important. That is why we worked closely with other equipment manufacturers to predict the energy required by the entire system. We used this information to create patented control logic for optimizing the HVAC system efficiency.

The building owner's challenge is to tie components and applications expertise into a single reliable system that provides maximum comfort, control and efficiency. Trane's Integrated Comfort™ systems (ICS) are a concept that combines system components, controls and engineering applications expertise into a single, logical and efficient system. These advanced controls are fully commissioned and available on every piece of Trane equipment, from the largest chiller to the smallest VAV box. As a manufacturer, only Trane offers this universe of equipment, controls and factory installation and verification.

Features and Benefits

Two-Stage Compressor Widens the Application Range

Why Centrifugal Compressors Surge
Centrifugal compressors produce their pressure differential (head) by converting the kinetic energy of the gas leaving the impeller into static pressure. The velocity of this gas is the result of two components:

- The radial velocity component V_r , which is directly proportional to the refrigerant gas flow Q .
- The tangential velocity component V_t , which is a function of both impeller diameter D and the rotational speed rpm.

The length of the resultant vector V is proportional to the kinetic energy available for conversion to static pressure in the volute. Consequently, for a given compressor, V_t is fixed and V_r varies with the cooling load. With the chiller unloading, the pressure differential between evaporator and condenser decreases. The compressor matches the new load and the lower "head" by closing the inlet guide vanes.

This reduces the gas flow it draws in and modifies its direction. Component V_r decreases accordingly, the vector diagram shifts and at some point, the balance of forces breaks down.

As pressurized gas rushes backwards through the impeller, the pressure in the gas passages falls, allowing the compressor to restore the balance of forces. If the process repeats itself, the compressor is said to surge.

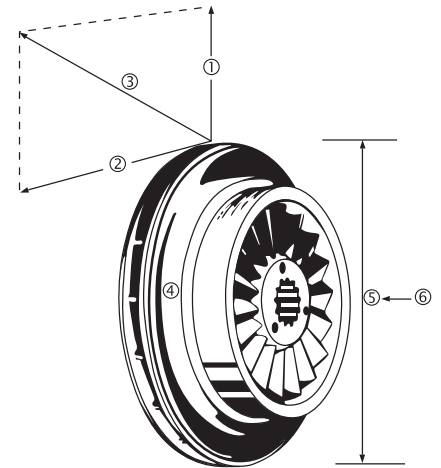

- 1 - $V_t = f(Q)$
- 2 - $V_r = f(D, \text{RPM})$
- 3 - $V = \text{Resultant}$
- 4 - RPM
- 5 - D
- 6 - Q

Two-Stage Compressors Surge Less and Later

To produce the same head as a single-stage compressor, two-stage machines use two small diameter impellers. Component V_t is the same as on each stage, though V_r is the same as on a single-stage compressor. This results in a better balance of forces at low loads and produces a machine with a wider unloading capability.

In Trane centrifugal chillers, gas prerotation vanes ahead of the compression stage improve impeller aerodynamic efficiency, resulting in smoother unloading and reducing power consumption.

The curves show that two-stage compressors surge less and later than single-stage machines. Intersection point B, when the load line meets the surge area, corresponds to a higher part load for the single-stage compressor than would be the case with a two-stage compressor. Two stage machines, therefore, have a wider range of applications.

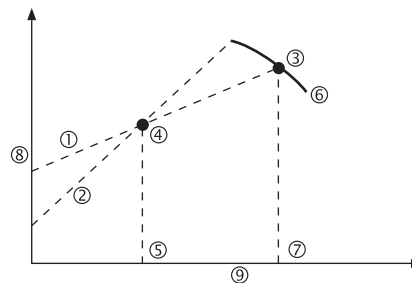

- 1 - Load Line
- 2 - Surge Line
- 3 - A
- 4 - B
- 5 - 40%
- 6 - 90° Vanes
- 7 - 100%
- 8 - Compressor Head
- 9 - Refrigerant Gas Flow

Typical single-stage compressor performance curve

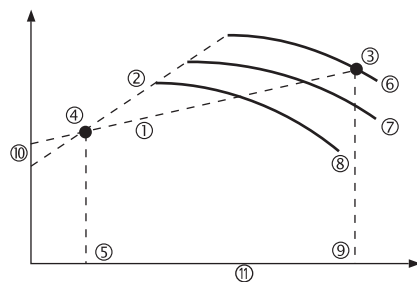

- 1 - Load Line
- 2 - Surge Line
- 3 - A
- 4 - B
- 5 - 20%
- 6 - 90°
- 7 - 80°
- 8 - 70° Vanes
- 9 - 100%
- 10 - Compressor Head
- 11 - Refrigerant Gas Flow

Typical two-stage compressor performance curve

Application Considerations

Condenser Water Limitations

Temperature

Trane centrifugal chillers start and operate over a range of load conditions with controlled water temperatures. Reducing the condenser water temperature is an effective method of lowering the chiller power input. However, the effect of lowering the condenser water temperature may cause an increase in system power consumption.

In many applications Trane centrifugal chillers can start and operate without control of the condenser water temperature. However, for optimum system power consumption, and for any applications with multiple chillers, control of the condenser water circuit is recommended. Integrated control of the chillers, pumps and towers is easily accomplished with Trane's CH530 and/or Tracer system.

Chillers are designed to ARI conditions of 29.4°C (85°F), but Trane centrifugal chillers can operate to a five psig pressure differential between the condenser and evaporator at any steady state load without oil loss, oil return, motor cooling, refrigerant hang-up problems. And this differential can equate to safe minimum entering condenser water temperatures at or below 12.8°C (55°F), dependent on a variety of factors such as load, leaving evaporator temperature and component combinations. Start-up below this differential is possible as well, especially with CH530 soft start features

Water Pumps

Avoid specifying or using 3600 rpm condenser and chilled water pumps. Such pumps may operate with objectionable noises and vibrations. In addition, a low frequency beat may occur due to the slight difference in operating rpm between water pumps and centrifugal motors. Where noise and vibration-free operation are important, The Trane Company encourages the use of 1750 rpm pumps.

Water Flow

Today's technology challenges ARI's traditional design of three gpm per ton through the condenser. Reduced condenser flows are a simple and effective way to reduce both first and operating costs for the entire chiller plant. This design strategy will require more effort from the chiller. But pump and tower savings will typically offset any penalty. This is especially true when the plant is partially loaded or condenser relief is available.

In new systems, the benefits can include dramatic savings with:

- Size and cost for condenser lines and valves
- Size and cost of the cooling tower.
- Size and cost of the water pumps.
- Pump energy (30 to 35% reduction).
- Tower fan energy(30 to 35% reduction).

Replacement chiller plants can reap even greater benefits from low flow condensers. Because the water lines and tower are already in place, reduced flows would offer a tremendous energy advantage. Theoretically, a 2 GPM/ton design applied to a system that originally used 3 GPM/ton would offer a 70% reduction in pump energy. At the same time, the original tower would require a nozzle change but would then be able to produce about two degrees colder condenser water than before. These two benefits would again typically offset any extra effort required by the chiller.

Contact your local Trane Sales Office for information regarding optimum condenser water temperatures and flow rates for a specific application.

Water Treatment

The use of untreated or improperly treated water in a chiller may result in scaling, erosion, corrosion, algae or slime. It is recommended that the services of a qualified water treatment specialist be used to determine what treatment, if any, is advisable. The Trane Company assumes no responsibility for the results of untreated, or improperly treated water.

General Data

Table GD-1 – Model CVGF Description

Model		CVGF							
Nominal Cooling Capacity		NTON	400	500	500	650	800	1000	
Heat Exchanger Size									
Evaporator	EVSZ	500	500	700	700	1000	1000		
Condenser	CDSZ	500	500	700	700	1000	1000		
Heat Exchanger Bundles									
Evaporator	EVBS	A = Small B = Medium C = Large	A = Small B = Medium C = Large	A = Small B = Medium C = Large	A = Small B = Medium C = Large	A = Small B = Medium C = Large D = Extra Large	A = Small B = Medium C = Large D = Extra Large	A = Small B = Medium C = Large D = Extra Large	
Condenser	CDBS	A = Small B = Medium C = Large	A = Small B = Medium C = Large	A = Small B = Medium C = Large	A = Small B = Medium C = Large	A = Small B = Medium C = Large D = Extra Large	A = Small B = Medium C = Large D = Extra Large	A = Small B = Medium C = Large D = Extra Large	
Heat Exchanger Tube									
Evaporator	EVTM	IE25 - 0.635 mm W 25.4 mm Internally Enhanced (IE25 - 0.025" W 1.00" Internally Enhanced) TE25 - 0.635 mm W 19 mm Internally Enhanced (TE25 - 0.025" W 0.75" Internally Enhanced)							
Condenser	CDTM	IE28 - 0.711 mm W 25.4 mm Internally Enhanced (IE28 - 0.028" W 1.00" Internally Enhanced) TE28 - 0.711 mm W 19 mm Internally Enhanced (TE28 - 0.028" W 0.75" Internally Enhanced)							
Evap/Cond Working Pressure								10	
bar								150	
psi									
Evap/Cond Water Connection		Victaulic Connection Flanged Adaptor (English Unit) Flanged Adaptor (SI Unit)							
Agency Approvals (Chiller)		UL-CUL Listed/ASME CE Approval/PED (European Code)							
Motor Volt/Hz		380/400/415/3300/6600 Volts – 50 Hz 380/460/575/3300/4160 Volts – 60 Hz							
Starter*		Wye-Delta, Solid-State Inside the Delta							
Unit Mounted		Wye-Delta, Solid-State Inside the Delta, *Across-the-line, *Primary Reactor, *Auto Transformer							
Remote Mounted		Wye-Delta, Solid-State Inside the Delta, *Across-the-line, *Primary Reactor, *Auto Transformer							

Table GD-2 – Weight

Model	Compressor	Shell Size		Without Starter				With Starter			
		Evaporator	Condenser	Operating		Shipping		Operating		Shipping	
				lbs	kgs	lbs	kgs	lbs	kgs	lbs	kgs
CVGF	400 - 500	500	500	22391	10157	19656	8916	23336	10585	20601	9345
CVGF	500	700	700	29438	13353	25593	11609	30383	13782	26538	12038
CVGF	650	700	700	30889	14011	27044	12267	31765	14409	27920	12665
CVGF	800	1000	1000	41646	18891	35627	16160	42522	19288	36503	16558
CVGF	1000	1000	1000	42462	19261	36443	16531	43407	19689	37388	16959

**Note: Values represent estimate maximum unit weights including shells with TECU tubes, max bundles, 2 pass evaporator and condenser, 150 psig non-marine waterboxes, and compressors with the largest, low voltage motors for each family.



General Data

50 and 60 Hz SI Units and (English Units)

Table GD-3 – Evaporator and Condenser Flow rates
(Minimum and Maximum, liters per second, gallons per minute)

High Efficiency Shells - 0.75 inch (19 mm) Int. Enhanced Cu Tube:										
Condenser:										
Nominal Shell	500	500	500	700	700	700	1000	1000	1000	1000
Bundle Size	Small	Medium	Large	Small	Medium	Large	Small	Medium	Large	Extra Large
Number of Passes	2	2	2	2	2	2	2	2	2	2
Min Flow lps (gpm)	31 (487)	34 (542)	37 (586)	42 (668)	47 (744)	52 (816)	59 (938)	67 (1056)	74 (1176)	77 (1213)
Max Flow lps (gpm)	113 (1786)	125 (1987)	136 (2148)	155 (2450)	172 (2727)	189 (2993)	217 (3441)	244 (3874)	272 (4311)	280 (4447)
Evaporator:										
Nominal Shell	500	500	500	700	700	700	1000	1000	1000	1000
Bundle Size	Small	Medium	Large	Small	Medium	Large	Small	Medium	Large	Extra Large
Number of Passes	2	2	2	2	2	2	2	2	2	2
Min Flow lps (gpm)	26 (407)	29 (458)	32 (511)	36 (566)	40 (628)	44 (698)	52 (822)	58 (921)	64 (1021)	72 (1136)
Max Flow lps (gpm)	94 (1493)	106 (1680)	118 (1873)	131 (2077)	145 (2304)	161 (2559)	190 (3013)	213 (3377)	236 (3745)	263 (4165)
Evaporator:										
Nominal Shell	500	500	500	700	700	700	1000	1000	1000	1000
Bundle Size	Small	Medium	Large	Small	Medium	Large	Small	Medium	Large	Extra Large
Number of Passes	3	3	3	3	3	3	3	3	3	3
Min Flow lps (gpm)	17 (271)	19 (305)	21 (340)	24 (378)	26 (419)	29 (465)	35 (548)	39 (614)	43 (681)	48 (757)
Max Flow lps (gpm)	63 (995)	71 (1120)	79 (1248)	87 (1385)	97 (1536)	108 (1706)	127 (2009)	142 (2251)	158 (2497)	175 (2777)
Standard Efficiency Shells - 1.00 inch (25.4 mm) Int. Enhanced Cu Tube:										
Condenser:										
Nominal Shell	500	500	500	700	700	700	1000	1000	1000	1000
Bundle Size	Small	Medium	Large	Small	Medium	Large	Small	Medium	Large	Extra Large
Number of Passes	2	2	2	2	2	2	2	2	2	2
Min Flow lps (gpm)	31 (499)	35 (557)	38 (606)	43 (682)	48 (764)	53 (838)	58 (925)	64 (1020)	75 (1172)	83 (1307)
Max Flow lps (gpm)	115 (1831)	129 (2041)	140 (2221)	158 (2501)	177 (2801)	194 (3071)	214 (3391)	236 (3741)	276 (4372)	302 (4792)
Evaporator:										
Nominal Shell	500	500	500	700	700	700	1000	1000	1000	1000
Bundle Size	Small	Medium	Large	Small	Medium	Large	Small	Medium	Large	Extra Large
Number of Passes	2	2	2	2	2	2	2	2	2	2
Min Flow lps (gpm)	28 (447)	31 (496)	35 (550)	39 (625)	45 (706)	49 (784)	49 (781)	57 (896)	63 (1003)	70 (1115)
Max Flow lps (gpm)	103 (1638)	115 (1818)	127 (2018)	145 (2293)	163 (2589)	181 (2874)	181 (2864)	207 (3287)	232 (3678)	258 (4090)
Evaporator:										
Nominal Shell	500	500	500	700	700	700	1000	1000	1000	1000
Bundle Size	Small	Medium	Large	Small	Medium	Large	Small	Medium	Large	Extra Large
Number of Passes	3	3	3	3	3	3	3	3	3	3
Min Flow lps (gpm)	19 (298)	21 (330)	23 (367)	26 (417)	30 (471)	33 (523)	33 (521)	38 (598)	42 (669)	47 (744)
Max Flow lps (gpm)	69 (1092)	76 (1212)	85 (1346)	96 (1529)	109 (1726)	121 (1916)	120 (1909)	138 (2191)	15 (2452)	172 (2726)

Jobsite Connections

Supply and Motor Lead Wiring and Connections

Copper conductors only should be connected to the compressor motor due to the possibility of galvanic corrosion as a result of moisture if aluminum conductors are used. Copper conductors are recommended for supply leads in the starter panel.

Suggested starter panel line and load side lug sizes (when lugs are provided) are noted in the starter submittals. These submitted lug sizes should be carefully reviewed for compatibility with conductor sizes specified by the electrical engineer or contractor. If they are not compatible, the electrical engineer or contractor should specify the required lug sizes for the particular application. Ground lugs are provided in the motor terminal box and starter panel. The motor terminals are supplied with connection pads which will accommodate bus bars or standard terminal lugs (crimp type recommended). **Terminal lugs are field-supplied.** These connection pads provide additional surface area to minimize improper electrical connections. Also, a $\frac{3}{8}$ -inch bolt is provided on all connection pads for mounting the lugs. Figure J-1 illustrates the connection between the motor connection pads and the terminal lugs.

Figure J-1 — Electric Connections

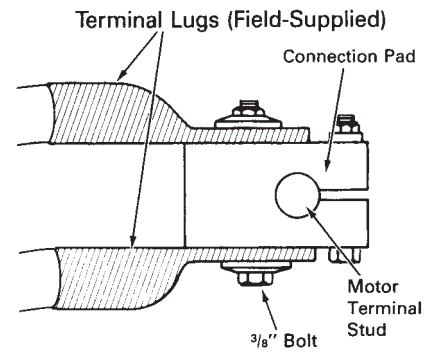

Shipment and Assembly

All style hermetic centrifugal units ship as a factory assembled, factory tested package, ready to rig into place on factory supplied isolation pads.

Controls

Standard Features

Standard Features

Field Connection

The field-connected elements are involved in physically turning the chiller on or off. This involves ensuring that the chiller is not in an emergency or external stop condition, starting the pumps, and verifying that flow has been established. The optional, factory-supplied flow switch or a customer-supplied differential-pressure switch can be used to prove flow.

Heat Exchanger Control

Fundamental internal variables that are necessary to control the chiller are gathered and acted upon by the heat exchanger control function.

Motor Control and Compressor Protection

This includes all functions that start, run, and stop the motor. The starter module provides the interface and control of Y-delta, across-the-line, primary reactor, autotransformer, and solid-state starters. The motor control also provides protection to both the motor and the compressor.

Phase Voltage Sensors – 3 phase

Includes factory-installed potential transformers in the starter for monitoring and displaying phase voltage and provides over/undervoltage protection. DynaView, TechView and Tracer Summit display the following:

- Compressor phase voltage (a-b, b-c, c-a)
- Kilowatts
- Power factor (uncorrected)

Chilled-Water Reset

Chilled-water reset reduces energy consumption during periods of the year when heating loads are high and cooling loads are reduced. It is based on return chilled-water temperature. Resetting the chilled-water temperature reduces the amount of work that the compressor must do by increasing the evaporator refrigerant pressure. This increased evaporator pressure reduces the pressure differential the compressor must generate while in the heat recovery mode. Chilled-water reset is also used in combination with the hot-water control. By resetting the chilled-water temperature upward, the compressor can generate a higher condenser pressure, resulting in higher leaving hot-water temperatures.

Controls

Optional Features

Extended Operation Package

Select the extended-operation package for chillers that require *external*, hot water control, and/or base-loading capabilities. This package also includes a 4-20 mA or 0-10 Vdc analog input for a refrigerant monitor.

- External base-loading control input
- External base-loading setpoint
- External hot-water control input
- Refrigerant monitor input

Base-Loading Control

This feature allows an external controller to directly modulate the capacity of the chiller. It is typically used in applications where virtually infinite sources of evaporator load and condenser capacity are available and it is desirable to control the loading of the chiller. Two examples are industrial process applications and cogeneration plants. Industrial process applications might use this feature to impose a specific load on the facility's electrical system. Cogeneration plants might use this feature to balance the system's heating, cooling, and electrical generation.

All chiller safeties and Adaptive Control functions are in full effect when Base Loading is enabled. If the chiller approaches full current, the evaporator temperature drops too low, or the

condenser pressure rises too high, the controller's Adaptive Control logic limits the loading of the chiller to prevent the chiller from shutting down on a safety limit. These limits may prevent the chiller from reaching the load requested by the Base Loading signal.

An alternative and less radical approach to Base Loading indirectly controls chiller capacity. Artificially load the chiller by setting the chilled-water setpoint lower than it is capable of achieving. Then, modify the chiller's load by adjusting the current-limit setpoint. This approach provides greater safety and control stability because it leaves the chilled-water temperature-control logic in effect. The chilled-water temperature control responds more quickly to dramatic system changes and limits chiller loading prior to reaching an Adaptive Control limit.

Hot-Water Control

This feature allows an external controller to enable/disable and modulate the hot-water control mode. Occasionally, centrifugal chillers are used to provide heating as a primary mission. In this case the external controller or operator would select a hot-water temperature setpoint and the chiller capacity would be modulated to

maintain the setpoint. Heating is the primary mission and cooling is a waste product or a secondary mission. This technique provides application flexibility, especially in multiple-chiller plants in conjunction with undersized heating plants.

The chiller needs only one condenser for hot-water control, whereas Heat Recovery uses a secondary condenser.

Refrigerant Monitor

The Extended Operation package allows for a refrigerant monitor to send a 4-20 mA signal to the DynaView display. It can be calibrated to correspond to either 0-100 ppm or 0-1,000 ppm concentration levels. The concentration level is displayed at DynaView, but the chiller will not take any action based on the input from the refrigerant monitor.

Alternatively, a refrigerant monitor can be connected to Tracer Summit, which has the ability to increase ventilation in the equipment room in response to high refrigerant concentrations.

Controls

Standard Protections

Tracer™ Chiller Controller

The chiller controller uses proportional-integral-derivative (PID) control for all limits—there is no dead band. This removes oscillation above and below setpoints and extends the capabilities of the chiller.

Some of the standard protection features of the chiller controller are described in this section. There are additional protection features not listed here.

High Condenser-Pressure Protection

The chiller controller's condenser limit keeps the condenser pressure under a specified maximum pressure. The chiller runs all the way up to 100 percent of the setpoint before reducing capacity using its adaptive control mode.

Starter-Contactor Failure Protection

The chiller will protect itself from a starter failure that prevents the compressor motor from disconnecting from the line to the limits of its capabilities.

The controller starts and stops the chiller through the starter. If the starter malfunctions and does not disconnect the compressor motor from the line when requested, the controller will recognize the fault and attempt to protect the chiller by operating the evaporator-and condenser-water pumps and attempting to unload the compressor.

Loss of Water-Flow Protection

The chiller controller has an input that will accept a contact closure from a proof-of-flow device such as a flow switch or pressure switch. Customer wiring diagrams also suggest that the flow switch be wired in series with the cooling-water (condenser-water) pump starter's auxiliary contacts. When this input does not prove flow within a fixed time during the transition from Stop to Auto modes of the chiller, or if the flow is lost while the chiller is in the Auto mode of operation, the chiller will be inhibited from running by a nonlatching diagnostic.

Evaporator Limit Protection

Evaporator Limit is a control algorithm that prevents the chiller tripping on its low refrigerant-temperature cutout. The machine may run up to the limit but not trip. Under these conditions the intended chilled-water setpoint may not be met, but the chiller will do as much as it can. The chiller will deliver as much cold water as possible even under adverse conditions.

Low Evaporator-Water Temperature

Low evaporator-water temperature protection, also known as Freeze Stat protection, avoids water freezing in the evaporator by immediately shutting down the chiller and attempting to operate the chilled-water pump. This protection is somewhat redundant with the Evaporator Limit protection, and prevents freezing in the event of extreme errors in the evaporator-refrigerant temperature sensor.

The cutout setting should be based on the percentage of antifreeze used in the customer's water loop. The chiller's operation and maintenance documentation provides the necessary information for percent antifreeze and suggests leaving-water temperature-cutout settings for a given chilled-water temperature setpoint.

Oil-Temperature Protection

Low oil temperature when the oil pump and/or compressor are running may be an indication of refrigerant diluting the oil. If the oil temperature is at or below the low oil-temperature setpoint, the compressor is shut down on a latching diagnostic and cannot be started. The diagnostic is reported at the user interface. The oil heaters are energized in an attempt to raise the oil temperature above the low oil-temperature setpoint.

High oil-temperature protection is used to avoid overheating the oil and the bearings.

Low Differential Oil-Pressure Protection

Oil pressure is indicative of oil flow and active oil-pump operation. A significant drop in oil pressure indicates a failure of the oil pump, oil leakage, or other blockage in the oil-circuit.

The differential pressure during oil pump, compressor prelube mode should not fall below 12 psid. A failure on this parameter generates a shutdown diagnostic. When the compressor is running, a diagnostic is issued when the differential pressure is lost.

Phase-Unbalance Protection

Phase-unbalance protection is based on an average of the three phase-current inputs. The ultimate phase-unbalance trip point is 30 percent. In addition, the RLA of the motor is derated by resetting the active current-limit setpoint based on the current unbalance. The RLA derate protection can be disabled in the field-startup menu.

The following derates apply when the phase-unbalance limit is enabled:

10% unbalance = 100% RLA derate
15% unbalance = 90% RLA derate
20% unbalance = 85% RLA derate
25% unbalance = 80% RLA derate
30% unbalance = Shutdown

Phase-Loss Protection

The controller will shut down the chiller if any of the three phase currents feeding the motor drop below 10 percent RLA. The shutdown will result in a latching phase-loss diagnostic. The time to trip is 1 second at minimum, 3 seconds maximum.

Phase Reversal/Rotation Protection

The controller detects reverse phase rotation and provides a latching diagnostic when it is detected. The time to trip is 0.7 seconds. Phase-rotation protection can be disabled in TechView.

Controls

Standard Protections

Momentary Power Loss and Distribution Fault Protection

Three-phase momentary power loss (MPL) detection gives the chiller improved performance through many different power anomalies. MPLs of 2.5 cycles or longer will be detected and cause the unit to shut down. The unit will be disconnected from the line within 6 line cycles of detection. If enabled, MPL protection will be active any time the compressor is running. MPL is not active on reduced-voltage starters from the initial start signal through transition. The MPL diagnostic is an automatic reset diagnostic. MPL protection can be disabled in TechView.

An MPL has occurred when the motor no longer consumes power. An MPL may be caused by any drop or sag in the voltage that results in a change in the direction of power flow. Different operating conditions, motor loads, motor size, inlet guide vane (IGV) position, etc. may result in different levels at which this may occur. It is difficult to define an exact voltage sag or voltage level at which a particular motor will no longer consume power, but we are able to make some general statements concerning MPL protection:

The chiller will remain running under the following conditions:

- Line-voltage sag of 1.5 line cycles or less for any voltage magnitude sag
- Control-voltage sags of less than 3 line cycles for any magnitude sag
- Control-voltage sags of 40 percent or less for any amount of time
- Second-order or lower harmonic content on the line

The chiller may shut down under the following conditions:

- Line-voltage sags of 1.5 or more line cycles for voltage dips of 30 percent or more
- Control-voltage sags of 3 or more line cycles for voltage dips of 40 percent or more
- Third-order or higher harmonic content on the line

Current Overload Protection

The control panel will monitor the current drawn by each line of the motor and shut the chiller off when the highest of the three line currents exceeds the trip curve. A manual reset diagnostic describing the failure will be displayed. The current overload protection does not prohibit the chiller from reaching its full-load amperage.

The chiller protects itself from damage due to current overload during starting and running modes, but is allowed to reach full-load amps.

High Motor-Winding Temperature Protection

This function monitors the motor temperature and terminates chiller operation when the temperature is excessive. The controller monitors each of the three winding-temperature sensors any time the controller is powered up, and displays each of the temperatures at the service menu. Immediately prior to start, and while running, the controller will generate a latching diagnostic if the winding temperature exceeds $265 \pm 5^\circ\text{F}$ ($129.4 \pm 2.8^\circ\text{C}$).

Surge Detection Protection

Surge detection is based on current fluctuations in one of three phases. The default detection criterion is two occurrences of RMS current change of 30 percent within 0.8 seconds in $60 + 10$ percent seconds. With the Tracer chiller controller, the detection criterion is adjustable.

Overvoltage and Undervoltage Protection

The unit will be shut down with an automatic reset if the line voltage is below or above 10 percent of nominal.

Must trip = 15 percent of nominal.

Time to trip = minimum of 1 minute, 10 seconds and maximum of 5 minutes, 20 seconds. Overvoltage and undervoltage protection can be disabled using TechView.

Power Factor and kW Measurement

Three-phase measurement of kW and unadjusted power factor yields higher accuracy during power imbalance conditions than with CH530.

Short-Cycling Protection

Short-cycling protection is based on a start-to-start time. This method uses a straight start-to-start timer to determine when to allow the next start.

A 'Restart Inhibit Start-to-Start Time' setpoint is used to set the desired start-to-start time. There is no 'free' start on a power up at DynaView. The real-time clock is used to determine when the next start will be allowed, based on the previous start.

When the start is inhibited by the restart-inhibit function, the time remaining is displayed along with the restart-inhibit mode.

Physical Dimensions

50 and 60 Hz SI (English Units)

Figure PD-1 – Model CVGF Cooling Only With Unit Mounted Starter

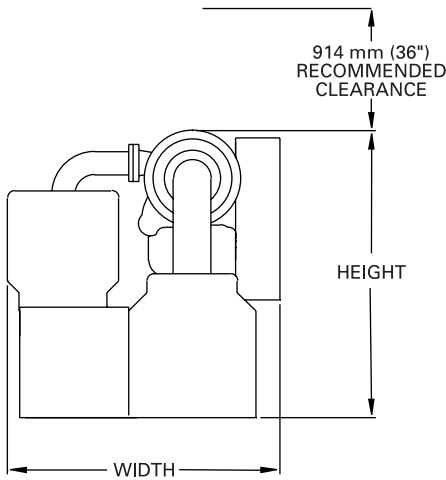
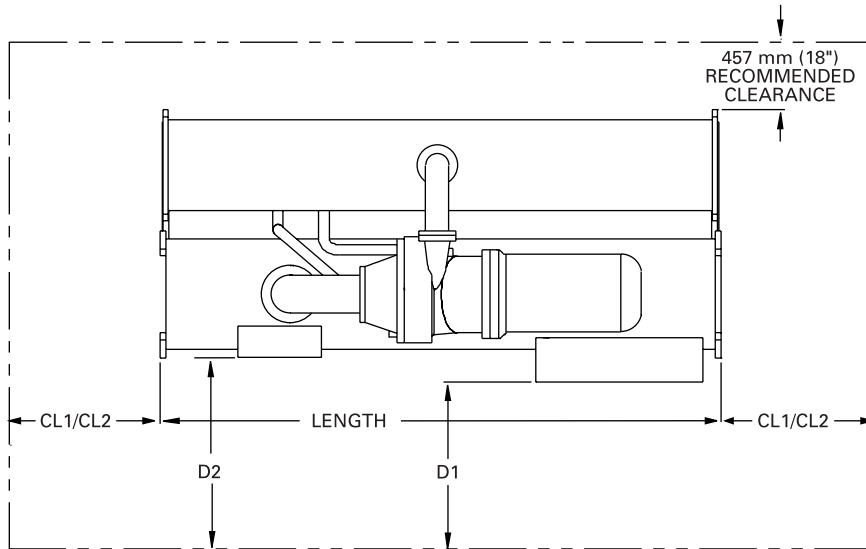
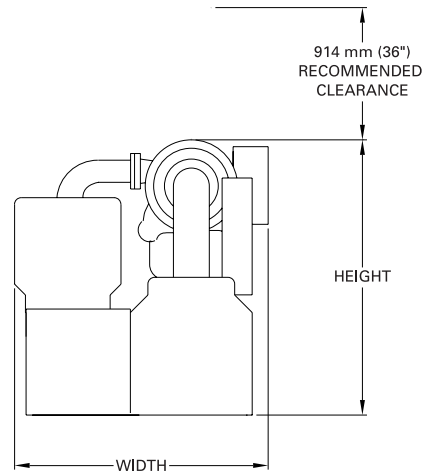

Figure PD-2 – Model CVGF Cooling Only Without Unit Mounted Starter (for Remote Mounted Starter)



Dimensions – SI Units (English Units)

Comp.	Shell Size	Clearance		Unit Dimensions			Unit Dimensions
		CL1	CL2	Length	Height	Width	Without Unit Mounted Starters
400-500	500	4235 mm (13' 10 3/4")	1118 mm (3' 8")	4083 mm (13' 4 3/4")	2094 mm (6' 10 1/2")	1984 mm (6' 6 1/8")	1929 mm (6' 3 15/16")
500	700	4235 mm (13' 10 3/4")	1850 mm (3' 11")	4083 mm (13' 4 3/4")	2200 mm (7' 2 5/8")	2038 mm (6' 8 1/4")	1988 mm (6' 6 1/4")
650	700	4235 mm (13' 10 3/4")	1850 mm (3' 11")	4083 mm (13' 4 3/4")	2270 mm (7' 5 3/8")	2083 mm (6' 10")	2076 mm (6' 9 3/4")
800-1000	1000	4235 mm (13' 10 3/4")	1219 mm (4')	4083 mm (13' 4 3/4")	2521 mm (8' 3 1/4")	2305 mm (7' 6 3/4")	2257 mm (7' 4 7/8")

CL1 at either end of machine and is required for tube pull clearance.
 CL2 is always at the opposite end of machine from CL1 and is for water box plus clearance.
 – Recommended clearance (D1) for machine with unit mounted starter is 914 mm (36")
 – Recommended clearance (D2) for machine without unit mounted starter is 1219 mm (38")
 Unit length is not included for the waterbox.
 See page 19 for waterbox dimension

Physical Dimensions

Model CVGF Water Connection Pipe Size

Water Passes	Shell Size		
	500	700	1000
	Metric Pipe Size (mm) DN		
Evaporator			
2 Pass	DN 200 (8")	DN 250 (10")	DN 300 (12")
3 Pass	DN 200 (8")	DN 200 (8")	DN 250 (10")
Condenser			
2 Pass	DN 250 (10")	DN 300 (12")	DN 350 (14")

Evaporator Water Box Length — SI (English)

Shell	Pressure	Evap.	No. Passes	Length mm (in)	
				Supply	Return
500	10 bar (150 psig)	NMAR	2	371 (14.61)	156 (6.14)
	10 bar (150 psig)	NMAR	3	371 (14.61)	371 (14.61)
700	10 bar (150 psig)	NMAR	2	489 (19.25)	235 (9.25)
	10 bar (150 psig)	NMAR	3	438 (17.24)	438 (17.24)
1000	10 bar (150 psig)	NMAR	2	581 (22.87)	276 (10.87)
	10 bar (150 psig)	NMAR	3	530 (20.87)	530 (20.87)

Condenser Water Box Length — SI (English)

Shell	Pressure	Evap.	No. Passes	Length mm (in)	
				Supply	Return
500	10 bar (150 psig)	NMAR	2	483 (19.02)	200 (7.87)
	10 bar (150 psig)	NMAR	2	438 (17.24)	222 (8.74)
700	10 bar (150 psig)	NMAR	2	581 (22.87)	213 (8.39)
	10 bar (150 psig)	NMAR	2	524 (20.63)	235 (9.25)
1000	10 bar (150 psig)	NMAR	2	654 (25.75)	232 (9.13)
	10 bar (150 psig)	NMAR	2	632 (24.88)	276 (10.87)

Mechanical Specifications

The Trane CVGF packaged centrifugal water chillers using HFC-134a refrigerant consist of a hermetic two stage, gear-drive centrifugal compressor, evaporator, condenser, interstage economizer, unit-mounted microprocessor based control panel and compressor motor starter. The chiller is completely factory assembled.

Compressor

Two-stage centrifugal compressor with high-strength aluminum alloy fully shrouded impellers. The impellers are tested at 25 percent over design operating speed. The rotating assembly is dynamically balanced for vibration of less than 5.1 mm/s (0.2 ips peak velocities) at nominal operating speeds. The control system affords 100 - 20 percent capacity modulation by electrically actuated guide vanes upstream of each impeller.

Drive Train

The drive train consists of helical bull and pinion gears. Gear tooth surfaces are case hardened and precision ground. The one-piece impeller shaft is supported by hydrodynamic thrust and radial bearings.

Motor

The motor is a hermetic, liquid refrigerant cooled, two-pole, low-slip squirrel cage induction motor. A radial hydrodynamic bearing and duplex angular contact ball bearings support the rotor assembly. Winding-embedded sensors provide positive thermal protection.

Lubrication System

The lubrication system consists of an internal oil sump with heaters, positive displacement oil pump, brazed plate condenser-cooled oil cooler, and oil distillation/return line.

Economizer/Orifice

The economizer consists of a carbon steel shell with internal components designed to prevent liquid carryover to the compressor. Liquid refrigerant is admitted through a single calibrated orifice (no moving parts) which maintains a pressure differential between condenser and economizer.

Evaporator

The evaporator is designed, tested and stamped in accordance with ASME Boiler and Pressure Vessel Code or PED (European Code) for refrigerant side working pressure of 15.2 bars (220 psig). It consists of a carbon steel shell

with steel tube sheets welded to each end. Intermediate tube support sheets positioned along the shell axis prevent relative tube motion. Individually replaceable externally finned and internally grooved 19 mm ($\frac{3}{4}$ in.) and 25.4 mm (1.0 in.) nominal diameter seamless copper tubes are mechanically expanded into tube sheets.

Two or three pass water boxes rated at 10.5 bar (150 psi) is standard. Grooved pipe stubs for Victaulic couplings are standard; flanged connections are optionally available. The waterside is hydrostatically tested at 1.5 times maximum working pressure.

Liquid refrigerant is admitted to the evaporator through a single calibrated orifice (no moving parts) which maintains a pressure differential between the economizer and the evaporator.

Condenser

The condenser is designed, tested and stamped in accordance with the ASME Boiler and Pressure Vessel Code or PED (European Code) for a refrigerant side working pressure of 15.2 bars (220 psig). It consists of a carbon steel shell with steel tube sheets welded to each end. Individually replaceable, externally finned and internally grooved 19 mm ($\frac{3}{4}$ in.) and 25.4 mm (1.0 in.) nominal diameter seamless copper tubes are mechanically expanded into the tube sheets.

Mechanical Specifications

Welded steel two pass water boxes are bolted to the tube sheets. Water connections are steel pipe stubs grooved for Victaulic couplings; flanged connections are optionally available. Maximum waterside working pressure of 10.5 bars (150 psi) is standard. The waterside is hydrostatically tested at 1.5 times maximum working pressure.

Unit Control Panel

The Tracer™ CH.530 is a microprocessor-based chiller controller that provides complete stand alone system control for water-cooled centrifugals. It is a factory-mounted packaged and tested on the CVGF unit. All controls necessary for the safe and reliable operation of the chiller are provided including oil management, interface to the starter, and three phase motor overload protection. It also includes comprehensive status and diagnostic monitoring controls. A control power transformer included in the starter panel powers the control system.

The microprocessor controller is compatible with reduced voltage or full voltage electro-mechanical starters, and solid state starter. Starter for Europe with the CE mark is available.

The microcomputer control system processes the leaving evaporator fluid temperature sensor signal to satisfy the system requirements across the entire load range.

The controller will load and unload the chiller via control of the stepper- motor/ actuator which drives the inlet guide vanes open and closed. The load range can be limited either by a control limit function such as motor current, low evaporator temperature or high condenser pressure limit or by an inlet guide vane limit (whichever comes first). It will also control the evaporator and condenser pumps to insure proper chiller operation.

Status and 10 active diagnostics are communicated to the operator via display with a tabbed navigation system. Setpoints are entered through the touch-sensitive screen. Countdown timer displays remaining time(s) during wait states and time out periods. Nonvolatile memory saves unit set-up information during power loss without the need for batteries. Password protection is provided to secure the operator interface. PC-based service tool software displays the last 60 active or 60 historic diagnostics, indicating the time, date of occurrence, and system parameters at the time of the diagnostic.

The service tool provides advanced troubleshooting and access to sophisticated configuration settings not needed during operation of the chiller. Any PC that meets the installation requirements may be loaded with the service tool software via download from www.trane.com.

Unit mounted display is capable of displaying chiller parameters in IP or SI units, and language in English and any 2 downloadable and/or locally translated languages.

Compressor Motor Starter

Unit-mounted starters can either be a star-delta or solid state in NEMA1 type enclosure wired to compressor motor up to 952 RLA at 380~480 volts (star-delta), 900 RLA at 481~600 Volts (star-delta), and 1472 RLA at 380~600 volts (solid-state).

Remote-mounted starters can either be star-delta or solid state for low voltage. Across-the-line, primary reactor, or auto transformer for medium and high voltage. All in a NEMA 1 type enclosure up to 1402 RLA at 380~600 volts (star-delta), 1472 RLA at 380~600 volts (solid-state), and 360 RLA at 3300~6600 volts (x-line, primary reactor, and auto-transformer).

Mechanical Specifications

Unit-mounted or remote-mounted starters for Europe (CE mark) will be star-delta, solid-state, across-the-line, primary reactor, and auto transformer only in a IP 20 enclosure.

A steel panel door with optional mechanical interlock disconnects the system when the door is opened (required for CE listing). The panel also contains three-phase current transformer for overload protection, and an oil pump starter with overloads. The starter is factory mounted and wired to the compressor motor and the control panel. The CVGF chiller/starter assembly is factory tested.

Optional remote mounted electromechanical starters are available.

Isolation Pads

Molded neoprene isolation pads are supplied with each chiller for placement under all support points. Spring isolators are optionally available.

Refrigerant and Oil Charge

A full charge of oil is supplied with each unit. The oil ships in the unit's sump and the refrigerant ships directly to the jobsite from refrigerant suppliers.

Painting

All painted CVGF surfaces are coated with two coats of air-dry beige primer-finisher prior to shipment.

Insulation

The chiller can be ordered with or without factory applied insulation. Factory supplied insulation is applied to

all low temperature surfaces including the evaporator, water boxes and suction elbow. Insulation material is 19 mm (¾ in.) Armaflex II or equal (thermal conductivity = 0.04 W/m·°C; 0.3 Btu·in/h-ft²·°F). The oil sump is insulated with 9.5 mm (⅜ in.) and 13 mm (½ in.) insulation respectively.

Rigging

Evaporator and condenser tube sheets provide rigging support points. A rigging diagram is affixed to the chiller.

Quality

The La Crosse chiller manufacturing facility is ISO 9001.

Conversion Table

To Convert From:	To:	Multiply By:	To Convert From:	To:	Multiply By:
Length			Energy and Power and Capacity		
Feet (ft)	meters (m)	0.30481	British Thermal Units (BTUH)	Kilowatt (kW)	0.000293
Inches (In)	millimeters (mm)	25.4	British Thermal Units (BTU)	KCalorie (Kcal)	0.252
Area			Tons (refrig. effect)	Kilowatt (refrig. effect)	3.516
Square Feet (ft ²)	square meters (m ²)	0.093	Tons (refrig. effect)	Kilocalories per hour (Kcal/hr)	3024
Square Inches (In ²)	square millimeters (mm ²)	645.2	Horsepower	Kilowatt (kW)	0.7457
Volume			Pressure		
Cubic Feet (ft ³)	Cubic meters (m ³)	0.0283	Feet of water (ftH ₂ O)	Pascals (PA)	2990
Cubic Inches (In ³)	Cubic mm (mm ³)	16387	Inches of water (inH ₂ O)	Pascals (PA)	249
Gallons (gal)	litres (l)	3.785	Pounds per square inch (PSI)	Pascals (PA)	6895
Gallons (gal)	cubic meters (m ³)	0.003785	PSI	Bar or KG/CM ²	6,895 x 10 ⁻²
Flow			Weight		
Cubic feet/min (cfm)	cubic meters/second (m ³ /s)	0.000472	Ounces (oz)	Kilograms (kg)	0.02835
Cubic Feet/min (cfm)	cubic meters/hr (m ³ /hr)	1.69884	Pounds (lbs)	Kilograms (kg)	0.4536
Gallons/minute (GPM)	cubic meters/hr (m ³ /hr)	0.2271	Fouling factors for heat exchangers		
Gallons/minute (GPM)	litres/second (l/s)	0.06308	0.00075 ft ² °F hr/BTU	= 0.132 m ² ° K/kW	
Velocity			0.00025 ft ² °F hr/BTU	= 0.044 m ² ° K/kW	
Feet per minute (ft/m)	meters per second (m/s)	0.00508			
Feet per second (ft/s)	meters per second (m/s)	0.3048			

Temperature – Centigrade (°C) Versus Fahrenheit (°F)

Note: The center columns of numbers, referred to as BASE TEMP., is the temperature in either degrees Fahrenheit (°F) or Centigrade (°C), whichever is desired to convert into the other. If degrees Centigrade is given, read degrees Fahrenheit to the right. If degrees Fahrenheit is given, read degrees Centigrade to the left.

Temperature			Temperature			Temperature			Temperature			Temperature		
°C	C or F	°F	°C	C or F	°F	°C	C or F	°F	°C	C or F	°F	°C	C or F	°F
-40.0	-40	-40.0	-15.0	+5	+41.0	+10.0	+50	+122.0	+35.0	+95	+203.0	+60.0	+140	+284.0
-39.4	-39	-38.2	-14.4	+6	+42.8	+10.6	+51	+123.8	+35.6	+96	+204.8	+60.6	+141	+285.8
-38.9	-38	-36.4	-13.9	+7	+44.6	+11.1	+52	+125.6	+36.1	+97	+206.6	+61.1	+142	+287.6
-38.3	-37	-34.6	-13.3	+8	+46.4	+11.7	+53	+127.4	+36.7	+98	+208.4	+61.7	+143	+289.4
-37.8	-36	-32.8	-12.8	+9	+48.2	+12.2	+54	+129.2	+37.2	+99	+210.2	+62.2	+144	+291.2
-37.2	-35	-31.0	-12.2	+10	+50.0	+12.8	+55	+131.0	+37.8	+100	+212.0	+62.8	+145	+293.0
-36.7	-34	-29.2	-11.7	+11	+51.8	+13.3	+56	+132.8	+38.3	+101	+213.8	+63.3	+146	+294.8
-36.1	-33	-27.4	-11.1	+12	+53.6	+13.9	+57	+134.6	+38.9	+102	+215.6	+63.9	+147	+296.6
-35.6	-32	-25.6	-10.6	+13	+55.4	+14.4	+58	+136.4	+39.4	+103	+217.4	+64.4	+148	+298.4
-35.0	-31	-23.8	-10.0	+14	+57.2	+15.0	+59	+138.2	+40.0	+104	+219.2	+65.0	+149	+300.2
-34.4	-30	-22.0	-9.4	+15	+59.0	+15.6	+60	+140.0	+40.6	+105	+221.0	+65.6	+150	+302.0
-33.9	-29	-20.2	-8.9	+16	+60.8	+16.1	+61	+141.8	+41.1	+106	+222.8	+66.1	+151	+303.8
-33.3	-28	-18.4	-8.3	+17	+62.6	+16.7	+62	+143.6	+41.7	+107	+224.6	+66.7	+152	+305.6
-32.8	-27	-16.6	-7.8	+18	+64.4	+17.2	+63	+145.4	+42.2	+108	+226.4	+67.2	+153	+307.4
-32.2	-26	-14.8	-7.2	+19	+66.2	+17.8	+64	+147.2	+42.8	+109	+228.2	+67.8	+154	+309.2
-31.7	-25	-13.0	-6.7	+20	+68.0	+18.3	+65	+149.0	+43.3	+110	+230.0	+68.3	+155	+311.0
-31.1	-24	-11.2	-6.1	+21	+69.8	+18.9	+66	+150.8	+43.9	+111	+231.8	+68.9	+156	+312.8
-30.6	-23	-9.4	-5.5	+22	+71.6	+19.4	+67	+152.6	+44.4	+112	+233.6	+69.4	+157	+314.6
-30.0	-22	-7.6	-5.0	+23	+73.4	+20.0	+68	+154.4	+45.0	+113	+235.4	+70.0	+158	+316.4
-29.4	-21	-5.8	-4.4	+24	+75.2	+20.6	+69	+156.2	+45.6	+114	+237.2	+70.6	+159	+318.2
-28.9	-20	-4.0	-3.9	+25	+77.0	+21.1	+70	+158.0	+46.1	+115	+239.0	+71.1	+160	+320.0
-28.3	-19	-2.2	-3.3	+26	+78.8	+21.7	+71	+159.8	+46.7	+116	+240.8	+71.7	+161	+321.8
-27.8	-18	-0.4	-2.8	+27	+80.6	+22.2	+72	+161.6	+47.2	+117	+242.6	+72.2	+162	+323.6
-27.2	-17	+1.4	-2.2	+28	+82.4	+22.8	+73	+163.4	+47.8	+118	+244.4	+72.8	+163	+325.4
-26.7	-16	+3.2	-1.7	+29	+84.2	+23.3	+74	+165.2	+48.3	+119	+246.2	+73.3	+164	+327.2
-26.1	-15	+5.0	-1.1	+30	+86.0	+23.9	+75	+167.0	+48.9	+120	+248.0	+73.9	+165	+329.0
-25.6	-14	+6.8	-0.6	+31	+87.8	+24.4	+76	+168.8	+49.4	+121	+249.8	+74.4	+166	+330.8
-25.0	-13	+8.6	0.0	+32	+89.6	+25.0	+77	+170.6	+50.0	+122	+251.6	+75.0	+167	+332.6
-24.4	-12	+10.4	+0.6	+33	+91.4	+25.6	+78	+172.4	+50.6	+123	+253.4	+75.6	+168	+334.4
-23.9	-11	+12.2	+1.1	+34	+93.2	+26.1	+79	+174.2	+51.1	+124	+255.2	+76.1	+169	+336.2
-23.3	-10	+14.0	+1.7	+35	+95.0	+26.7	+80	+176.0	+51.7	+125	+257.0	+76.7	+170	+338.0
-22.8	-9	+15.8	+2.2	+36	+96.8	+27.2	+81	+177.8	+52.2	+126	+258.8	+77.2	+171	+339.8
-22.2	-8	+17.6	+2.8	+37	+98.6	+27.8	+82	+179.6	+52.8	+127	+260.6	+77.8	+172	+341.6
-21.7	-7	+19.4	+3.3	+38	+100.4	+28.3	+83	+181.4	+53.3	+128	+262.4	+78.3	+173	+343.4
-21.1	-6	+21.2	+3.9	+39	+102.2	+28.9	+84	+183.2	+53.9	+129	+264.2	+78.9	+174	+345.2
-20.6	-5	+23.0	+4.4	+40	+104.0	+29.4	+85	+185.0	+54.4	+130	+266.0	+79.4	+175	+347.0
-20.0	-4	+24.8	+5.0	+41	+105.8	+30.0	+86	+186.8	+55.0	+131	+267.8	+80.0	+176	+348.8
-19.4	-3	+26.6	+5.5	+42	+107.6	+30.6	+87	+188.6	+55.6	+132	+269.6	+80.6	+177	+350.6
-18.9	-2	+28.4	+6.1	+43	+109.4	+31.1	+88	+190.4	+56.1	+133	+271.4	+81.1	+178	+352.4
-18.3	-1	+30.2	+6.7	+44	+111.2	+31.7	+89	+192.2	+56.7	+134	+273.2	+81.7	+179	+354.2
-17.8	0	+32.0	+7.2	+45	+113.0	+32.2	+90	+194.0	+57.2	+135	+275.0	+82.2	+180	+356.0
-17.2	+1	+33.8	+7.8	+46	+114.8	+32.8	+91	+195.8	+57.8	+136	+276.8	+82.8	+181	+357.8
-16.7	+2	+35.6	+8.3	+47	+116.6	+33.3	+92	+197.6	+58.3	+137	+278.6	+83.3	+182	+359.6
-16.1	+3	+37.4	+8.9	+48	+118.4	+33.9	+93	+199.4	+58.9	+138	+280.4	+83.9	+183	+361.4
-15.6	+4	+39.2	+9.4	+49	+120.2	+34.4	+94	+201.2	+59.4	+139	+282.2	+84.4	+184	+363.2

FOR INTERPOLATION IN THE ABOVE TABLE USE:

BASE TEMPERATURE (°F or °C)	1	2	3	4	5	6	7	8	9	10
DEGREES CENTIGRADE:	0.56	1.11	1.67	2.22	2.78	3.33	3.89	4.44	5.00	5.56
DEGREES FAHRENHEIT:	1.8	3.6	5.4	7.2	9.0	10.8	12.6	14.4	16.2	18.0

ISO 9001
Quality System
Certified



La Crosse
Business Unit



Trane
A business of American Standard Companies
www.trane.com

For more information contact your local sales office
or e-mail us at comfort@trane.com

Literature Order Number	CTV-PRC001-E4
File Number	PL-RF-CTV-000-PRC001-0303
Supersedes	CTV-PRC001-E4 1/03
Stocking Location	La Crosse-Inland

Trane has a policy of continuous product and product data improvement and reserves the right to change design and specifications without notice.

Société Trane – Société Anonyme au capital de 61 005 000 Euros – Siège Social: 1 rue des Amériques – 88190 Golbey – France – Siret 306 050 188-00011 – RSC Epinal B 306 050 188
Numéro d'identification taxe intracommunautaire: FR 83 3060501888