



Koolman Air-Cooled Water Chiller With Heat Pump Option

CGAK/R 030-150
9.8~39 kW



PKGP-PRC006-EN

Contents

Features and Benefits	4
Mechanical Specifications	5
Model Nomenclature	6
Performance Data	7
Dimensions	8
Typical System Pipeline Installation Diagram	10
Maintenance Space Diagram	11
Electrical Specifications	12
Water Pressure Drop Curve	13

Features and Benefits

Introduction

Using the leading high-efficiency hermetic scroll compressor and evaporator technology, Koolman provides you a stable, reliable and highly efficient operation. Matched with a large variety of fan coils of different sizes it can be widely used in top grade apartments, luxury villas, office buildings, small-sized restaurants, retail stores and hotels to create a comfortable and delightful indoor environment.

standard-type



State-of-the-art Appearance

Koolman boasts of its state-of-the-art appearance. The contemporary appearance, designed by expert designers, will be naturally integrated with the surrounding environment and will definitely display your prominent taste.

Space Saving

As a result of the particular slim design (standard type is 500mm thick while mini type is only 390mm thick), the unit can be installed directly on the veranda, rooftop or ground without the need to have a plant room.

Available Options

Either 220V or 380V is available for the mini-type and either 380V or 415V is available for the standard type. In addition, pressurized water tank and blue fin are available to meet various requirements.

Noise Level

Koolman uses low noise fans and

components to achieve its low noise level.

Free of Cooling Tower

Heat dissipation in the way of air cycle eliminates the need for cooling water tower. Thus, not only does it save the cost and space for cooling tower it also eliminates water shortage concerns.

Easy Installation

Each chiller is charged with full factory refrigerant and oil charge further reduces field labor, materials, and installation cost. All units are factory run tested. Only power supply and water piping are required to be connected on the jobsite.

Environmentally

Responsible Refrigerant

It uses the environmental responsible, non-CFC R407C refrigerant. R407c is a modern environmentally responsible refrigerant with a high COP performance.

mini-type



Mechanical Specifications

General

Koolman air-cooled liquid chiller is designed to couple with fan coil units and air handling units for residential or small commercial air conditioning application.

Units are composed of scroll compressor (s), plate type evaporator, finned-copper-tube and aluminum condenser, axial fan assembly, expansion valve, four-way reversal valve (heat pump only), indoor cold/warm control switch, water flow switch, filter dryer, sight-glass, integral water pump, galvanized sheet metal housing with powder paint and factory mounted controls.

Optional fittings include pressurized water tank system, and blue fins.

Compressor

Depending on capacity range, units come with single or double scroll compressors to cater for changing demand and efficient part load operations.



Evaporator

Evaporator is a compact brazed plate heat exchanger with AISI 316 stainless plates and adapters. A 20-mesh strainer is installed at the water inlet to protect the evaporator and unit against fouling. The strainer (factory provided, field installed) can be removed for cleaning.



Housing

All parts are fabricated to precision by state-of-the-art CNC machines. The frame design allows all panels to be removed for service without affecting the structure of the unit. The panels are made of galvanized steel plate with powder paint. All panels are internally insulated with single layer foam cell in order to reduce noise and vibration.

Water Pump

Pump is centrifugal type and adopts a mechanical shaft seal. Motor is fan cooled (TEFC), 2-pole induction type. Pump is installed in the unit to save installation space and also to reduce noise level.



Controls and Protection Devices

The controller contains all the basic electrical protection devices including electromagnetic switches, relays and current overload protectors. The

automatic control devices consist of high and low pressure switches, thermostatic and anti-freeze cutouts, which improve and protect the unit's normal operation. In addition, the preset low temperature protection command can start the machine automatically to protect the water pipes from freezing.

LCD Microprocessor-based Adjustable Water Temperature Control

Precise temperature control of inlet chilled water, operation modes and system protection are provided by the long-range controller. In addition, the password can be set and any abnormal condition will be monitored and captured to facilitate quick repair and normal operation. In addition, the interlocking function of the two-way valve is available.



Air-cooled Condenser

The unit comes with air-cooled fin-tube U or V shaped condensers. Copper tubes are of the 3/8" diameter, seamless type. Fins are aluminum with efficient Wavy fin. Copper tubes are expanded mechanically to bond with the fins for effective heat transfer. Light-weight axial flow fan(s) is (are) driven by high efficiency, low speed, low noise motor(s) to ensure quiet and reliable operation.



Model Nomenclature

C **G** **A** **R** **0** **7** **5** **7** **D** **B** **R** **N** **F** **N** **D**
 1 2 3 4 5 6 7 8 9 10 11 12 13 14 15

Digit 1,2,3 CGA=Air-cooled Water Chiller

Digit 4 K=Cooling Only
 R=Heat Pump

Digit 5,6,7 Model

- 030 (mini casing)
- 050 (mini casing)
- 060 (mini casing)
- 075
- 100
- 150

Digit 8 Power Supply

- 5=380V/50Hz/3PH
- 6=220V/50Hz/1PH (for 030 only)
- 7=415V/50Hz/3PH (for 075, 100, 150 only)

Digit 9 Manufacturing Code (defaulted by factory)

- A=030, 060 (mini casing)
- D=075; 150 double compressors
- F=050 (mini casing); 100; 150 single compressor

Digit 10 Controller

B=Microprocessor-based adjustable water temperature controller

Digit 11 Chilled Water Pump

R=Internal Pump

Digit 12 Supplement Water and Electric Heater

N=None

Digit 13 Applicable Ambient Temperature/Fin Options

- F=Standard ambient temperature/Al-fin (standard)
- E=Standard ambient temperature/Blue-fin

Digit 14 Fitting Options

N=None (standard option)

B=5 liters pressurized water tank (WTANK-5)

C=12 liters pressurized water tank (WTANK-12)

Note: Digit 14 is indicated as "N" prior to shipment. When the pressurized water tank is required, it shall be packed individually and the model number in the bracket shall be used.

Digit 15 Service Sequence

D=R407c refrigerant

Performance Data

Heat pump/cooling only(R407C)

item		model							
		CGAK/R-0306	CGAK/R-0305	CGAK/R-0505	CGAK/R-0605	CGAK/R-0755	CGAK/R-1005	CGAK/R-1505	CGAK/R-1505
cooling capacity	Kal/Hr	8,450	8,450	11,300	13,420	16,800	22,500	33,540	32,680
	kW	9.8	9.8	13.1	15.6	19.5	26.2	39	38
heating capacity	Kal/Hr	10,150	10,150	12,500	15,220	19,090	25,800	36,500	34,400
	kW	11.8	11.8	14.5	17.7	22.2	30	42.4	40
Voltage		220V/50Hz/1PH	380V/50Hz/3PH			380V or 415V/50Hz/3PH			
compressor	type	High-efficiency hermetic scroll							
	Number	1	1	1	1	1	2	2	1
	power input (Cooling/Heating) (kW)	2.90/3.35	2.90/3.35	4.2/4.5	5.43/5.7	6.2/6.6	8/8.4	12.5/12.6	12.2/12.8
	running current (Cooling/Heating) (A)	15.5/17	6.0/6.6	8.6/8.7	11.5/11.7	12.8/13.3	17.2/18.2	28/28	26.1/27.3
fan (axile flow type)	diameter (mm)	420	420	420	420	762	762	762	762
	number	2	2	2	2	1	1	2	2
	power input (kW)	0.2	0.2	0.2	0.2	0.6	0.6	1.2	1.2
	speed (RPM)	950	950	950	950	550	550	550	550
	air flow (CMH)	4,150	4,150	4,150	4,150	7,000	7,000	14,500	14,500
chilled water pump	type	multi-stage close couple centrifugal							
	power input (kW)	0.49	0.46	0.46	0.46	0.72	0.72	1.16	1.16
	discharge head (mHzO)	21	21	19	16	20	16	18	18
evaporator	type	Stainless steel plate							
	water flow (Cooling/Heating) (L/min)	27.7/33	27.7/33	37.5/41.6	44.7/50.7	55.9/63.6	75.1/86	111.8/121.5	109/115
protective device		overheat protection, high and low pressure protection, anti-freeze protection							
lubricant	type	MMMAPOE							
	charge (L)	1.242	1.36	1.952	1.774	2.51	2x1.952	2x2.514	4.14
refrigerant	type	R407C							
	charge (kg)	2.85	3.05	3.8	4.35	4.7	2x3.5	2x4.9	9.1
dimensions	height (mm)	1,285	1,285	1,285	1,285	1,900	1,900	1,900	1,900
	width (mm)	950	950	950	950	1,290	1,290	1,990	1,990
	depth (mm)	390				500			
water connectionØ (PT)		1"				1 1/4"			
operation weight (kg)		150	146	170	170	290	404	490	470

Note:

1. Cooling capacity is based on 35°C ambient temperature, 7°C outlet water temperature and 12°C inlet water temperature.

Heating capacity is based on 7°C ambient temperature, 45°C outlet water temperature and 40°C inlet water temperature.

Dimensions

Mini-type
CGAK/R-0305A/0306A/0505F/0605A (unit: mm)

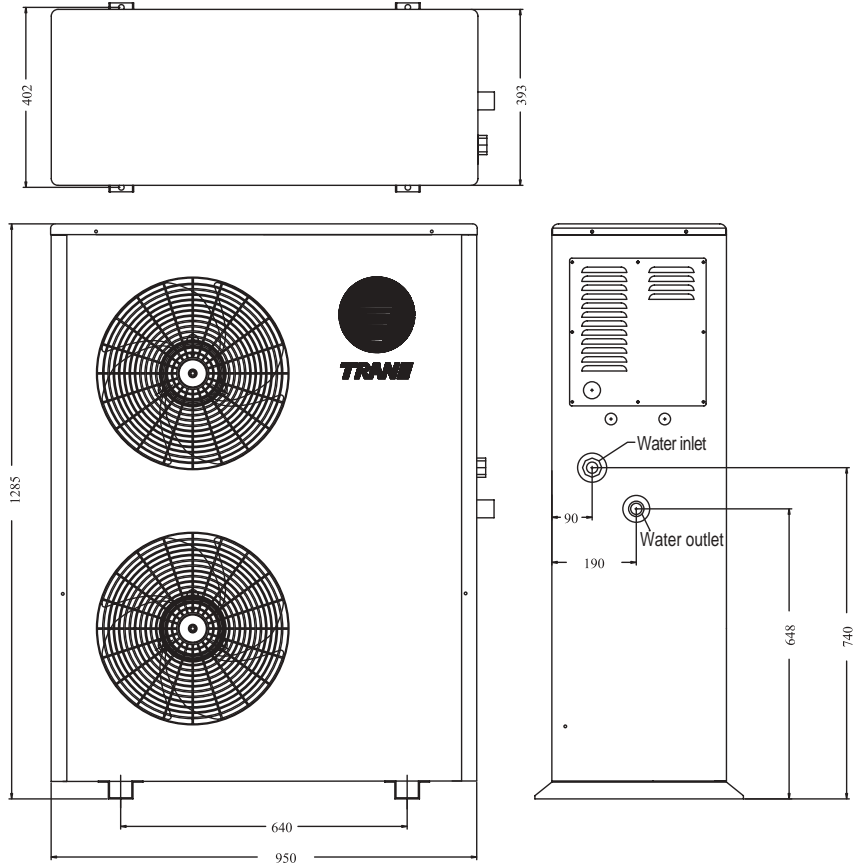

Typical System Pipeline Installation Diagram

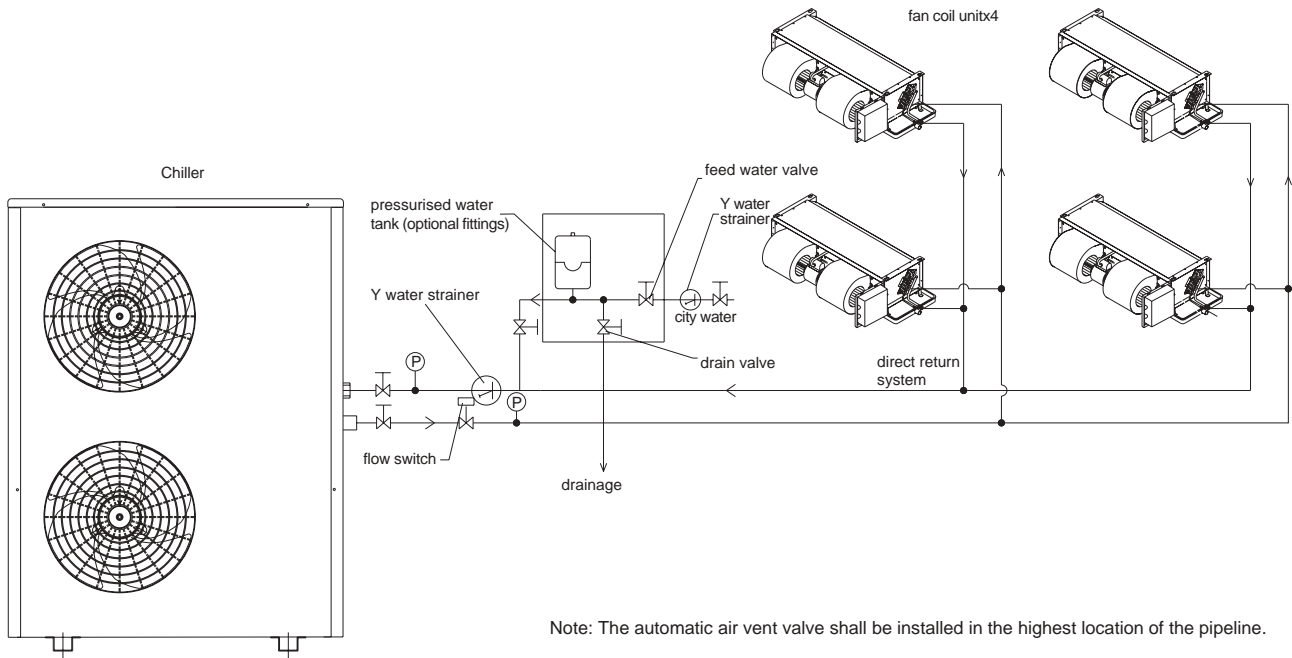

Description of the principle of the pressurized water tank:

1. In order to avoid the pipe cracking due to the system overpressure resulting from the change of ambient temperature and also to avoid the water hammer in the pipes, a pressurized water tank shall be added in the pipeline system.
2. In order to avoid the excessively high or low pressure in the pipe, an automatic feed water valve and an automatic drain valve are included in the pressurized water tank. The feed water pressure can be adjusted based on the field situation.
3. An open expansion tank can be installed in the highest location of the pipeline system based on the field situation.

Installation dimensions

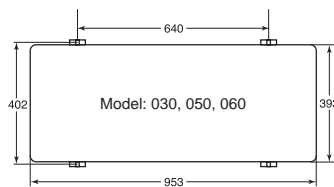
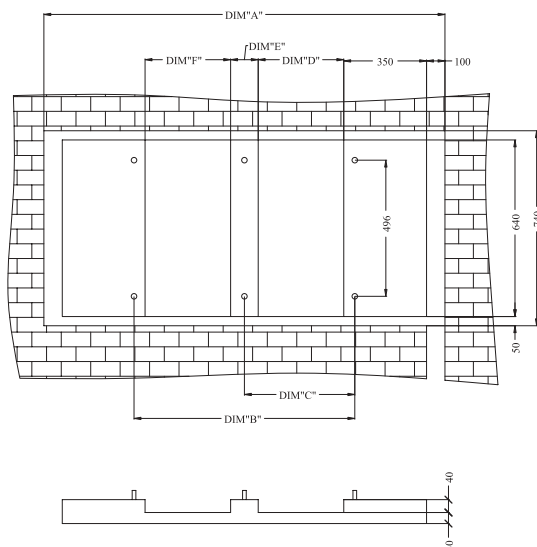

Model	A	B	C	D	E	F
075	1630	850	0	365	0	365
100	1630	850	0	365	0	365
150	2330	1550	775	640	150	640

Maintenance Space Diagram

Unit: mm

⇨ represent the flow direction

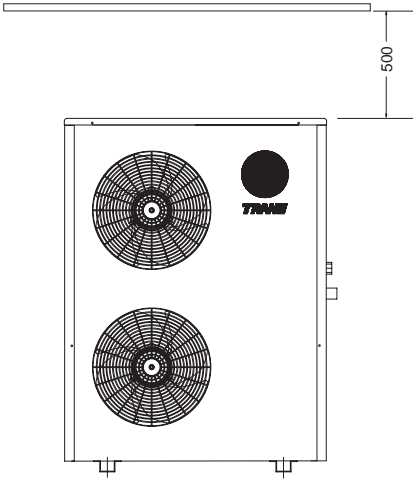
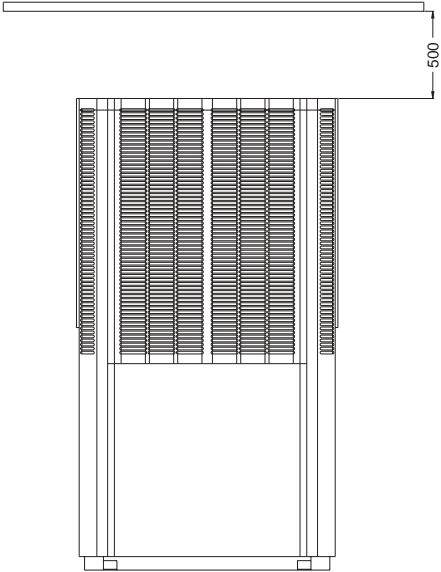
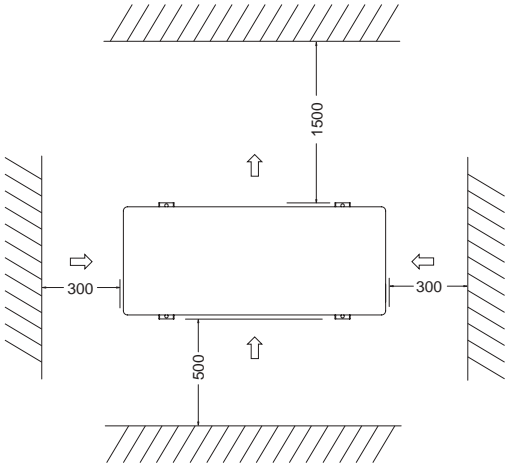
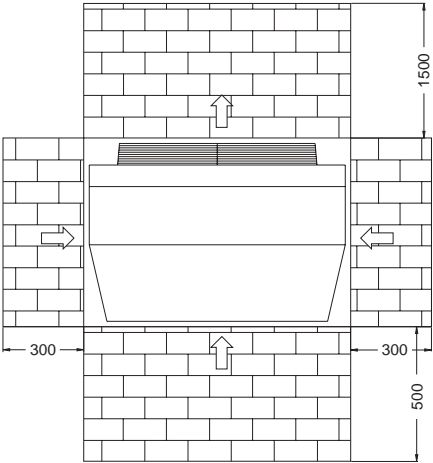

Electrical Specifications

MODEL	Voltage (V/Hz/PH)	Full-load current of the pump FLA	Rated current of No.1 compressor RLA	Rated current of No.2 compressor RLA	Rated current of No.1 fan FLA	Rated current of No.2 fan FLA	Minimum circuit current of the unit MCA	Recommend fuse specification REC	Maximum fuse specification MFS	Minimum diameter of the copper core of the power wire mm ²
0305A	380/50/3	1.1	7.2	-	0.52	0.52	11.2	12.9	18.3	2.5
0306A	220/50/1	2.4	16.3	-	0.52	0.52	23.8	27.9	40.1	6
0505F	380/50/3	1.1	8.5	-	0.52	0.52	12.8	14.9	21.3	4
0605A	380/50/3	1.1	11.2	-	0.52	0.52	16.2	18.9	27.3	4
0755D	380-415/50/3	1.4	11.6	-	1.6	-	17.5	20.4	29.1	6
1005F	380-415/50/3	1.4	7.4	7.4	1.6	-	21.5	25.2	36.3	6
1505D	380-415/50/3	2.6	11.6	11.6	1.6	1.6	34.8	40.6	58	10
1505F	380-415/50/3	1.8	25.8	-	1.6	1.6	37.3	43.7	63	10

- The difference between the power voltage and the standard voltage shall not exceed 10 percent of the standard value.
- Rated current(RLA)=the current of the machine under the ARI or UL standard conditions
- Minimum circuit current(MCA)=maximum loadx1.25+sum of the extra load (to decide the diameter of the wire)
- Recommended fuse specification(REC)=maximum loadx1.5+sum of the extra load (to select the fuse closest in specification)
- Maximum fuse specification(MFS)=maximum loadx2.25+sum of the extra load (to select the fuse same or smaller in specification)

LCD microprocessor-based adjustable water temperature controller



1. System function

- Cooling/heating switch
- Compressor and pump protection
- Two-way valve interlock
- Refrigerant high pressure protection for the plate heat exchanger
- EWT display/setting
- Timing on/off time

- Refrigerant system high/low pressure protection
- Anti-freeze protection of water system and plate heat exchanger in winter
- Malfunction alarm
- System operating status
- Defrosting interval/operation time setting

2. The factory provides standard 10 meters controller cable and optional 30 meters is available.

Water Pressure Drop Curve

Water pressure drop curve-50Hz

CGAK/R030

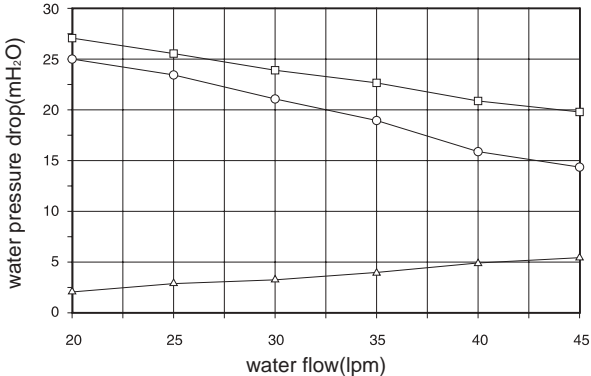

CGAK050,060

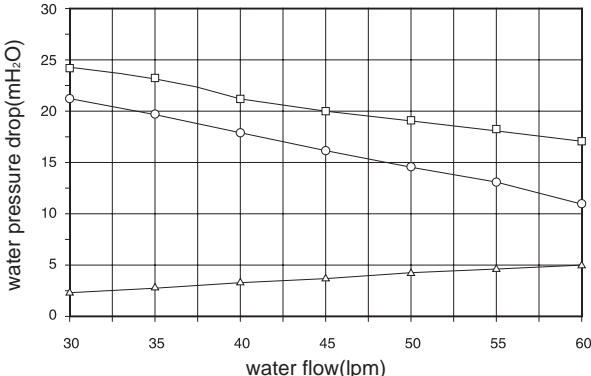

CGAK075

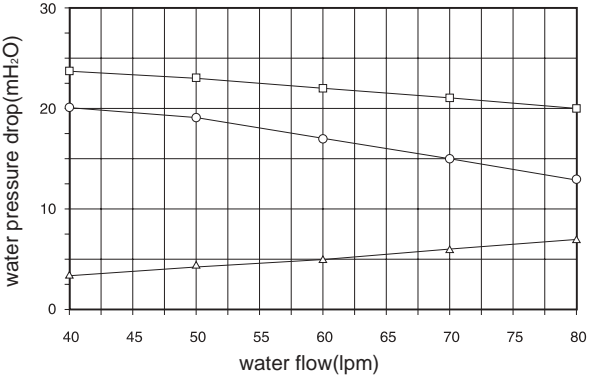

CGAK100

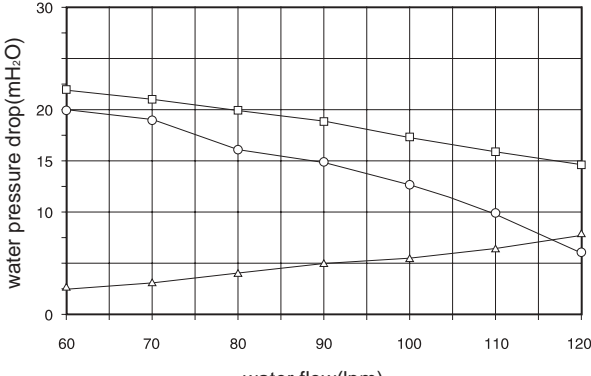

CGAK150

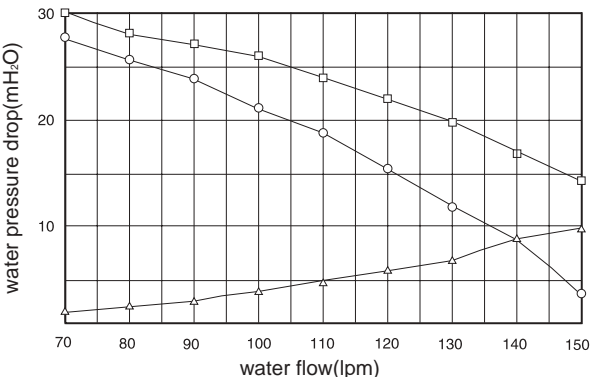

note: -□- pump head, -○- allowable external pressure loss, -△- internal pressure loss

Water Pressure Drop Curve

water flow rate

unit: liter/min (LPM)

model	Lower limit of water flow	Rated water flow	Upper limit of water flow
030	20.6	31	46.4
050	26.3	39.6	59.3
060	32.9	49.5	74.2
075	39.1	58.8	88.2
100	54.8	82.3	123.4
150	76.5	115	154.4

Water Pressure Drop

To measure the water pressure difference between the water inlet and outlet of the unit (including pump), pump head at a particular water flow rate may be read off from the pump head curve. Refer to curves to design piping system for standard models with pumps.

The inner water pressure drop of the unit without a pump (the pump is installed outside of the unit) should basically follow the graphs shown in the Water pressure drop curve section. Refer to curves to design piping system for models without pumps.

Water Flow

The chilled water flow through the unit shall be rated between the upper and lower limit listed in the table. If the chilled water flow is below the lower limit, the discontinuous water flow will reduce the evaporator heat transfer and make the expansion valve out of control or exceptional low-pressure shutdown. Contrarily, the inner parts of the evaporator will be eroded if the water flow is higher than the upper limit.



Trane
A business of American Standard Companies
www.trane.com

For more information, contact your local district office

Literature Order Number PKGP-PRC006-EN (July 2005)

File Number

Supersedes September 2004

Stocking location Taicang

Trane has a policy of continuous product and data improvement and reserves the right to change design specifications without notice.